

SIZE170 PULL, 170 PUSH TUBULAR SOLENOID

UNIT : mm
SHOWN ENERGIZED

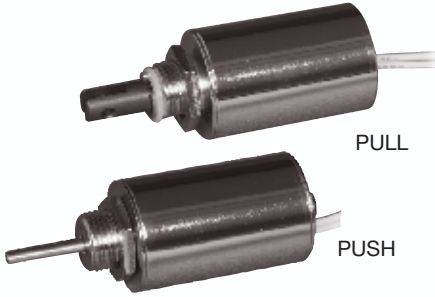

WEIGHT : 39g
PLUNGER
PULL : 5g
PUSH : 4g

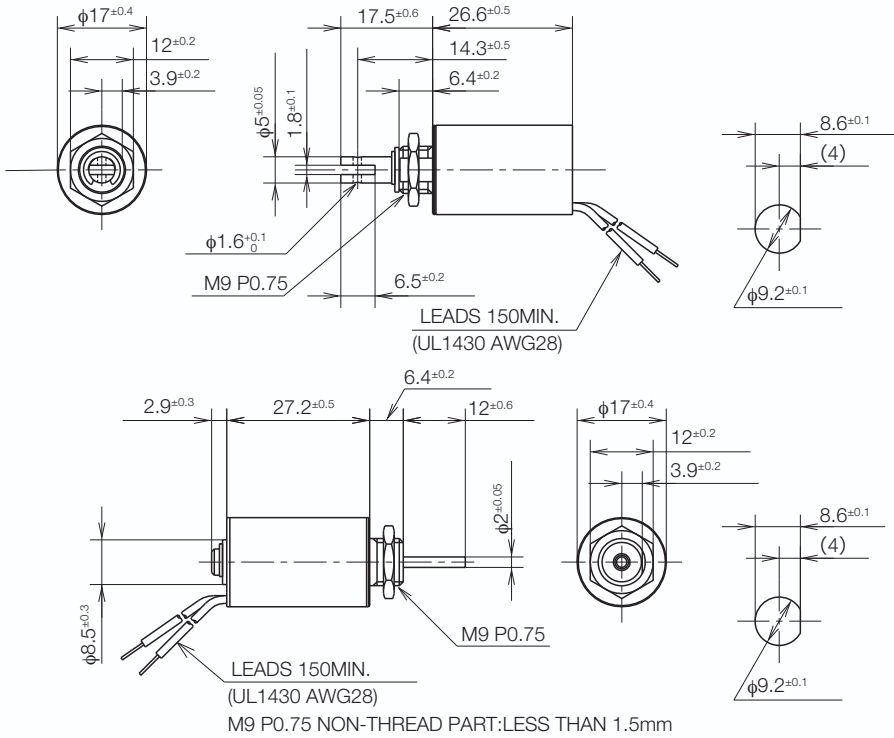
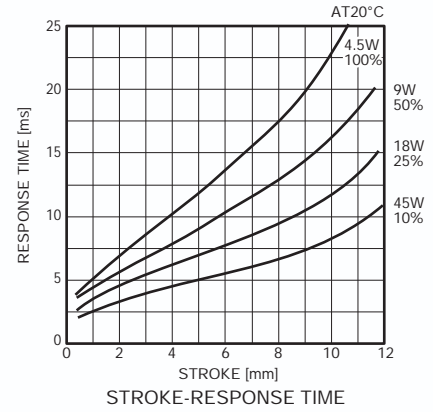
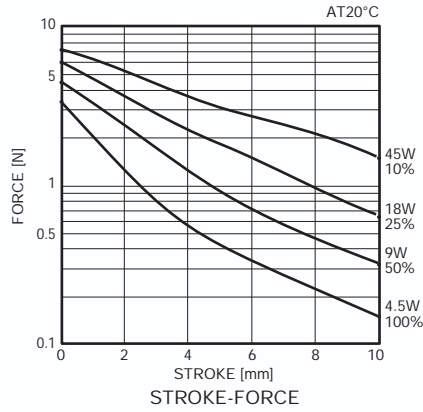

COIL DATA

Heat sink : 50×50×3mm aluminum

duty cycle= $\frac{\text{"on" time}}{\text{"on" time} + \text{"off" time}} \times 100\%$			100% continuous	50% or less	25% or less	10% or less
MAX. "on" time in seconds			∞	50	5	2
watts at 20°C			4.5	9	18	45
ampere-turns at 20°C			631	892	1262	1995
AWG no.	resistance $\Omega \pm 10\%$ (at 20°C)	no. turns	volts DC			
27	2.83	520	3.4	4.9	6.9	10.9
28	4.90	695	4.4	6.3	8.9	14.1
29	6.59	760	5.5	7.7	10.9	17.3
30	11.0	985	7.0	10.0	14.1	22
31	18.0	1246	9.1	12.9	18.2	29
32	28.2	1580	11.3	15.9	23	36
33	46.3	2080	14.0	19.9	28	44
34	68.5	2460	17.6	25	35	56
35	119	3260	23	33	46	73
36	177	3700	30	43	60	95
37	280	5000	35	50	71	112
38	408	6000	43	61	86	136
39	715	8080	56	79	112	177
40	1108	9700	72	102	144	228
41	1763	12000	93	131	185	293