

SIZE401 ROTARY SOLENOID

UNIT : mm

SHOWN DE-ENERGIZED, RIGHT HAND ROTATION



WEIGHT(ABD&R): 200g

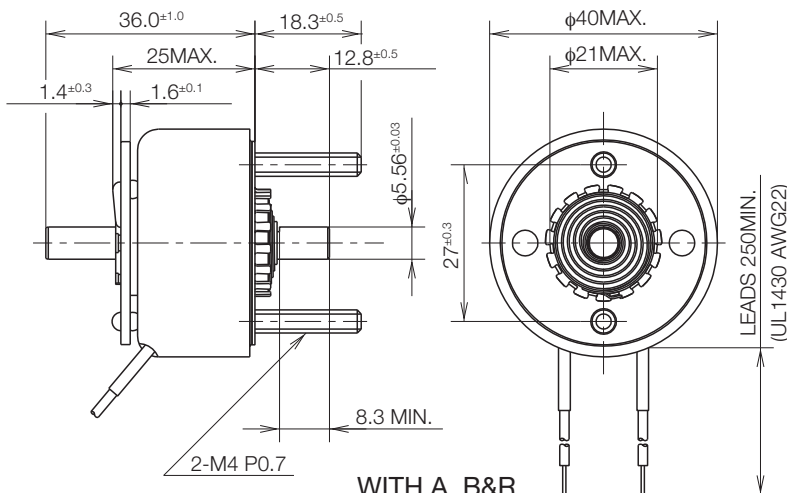

WITH A, B&R

1/2 ROTATION ANGLE ±3° TO LEFT OF CENTER FOR R.H.ROTATION, RIGHT OF CENTER FOR L.H.ROTATION.

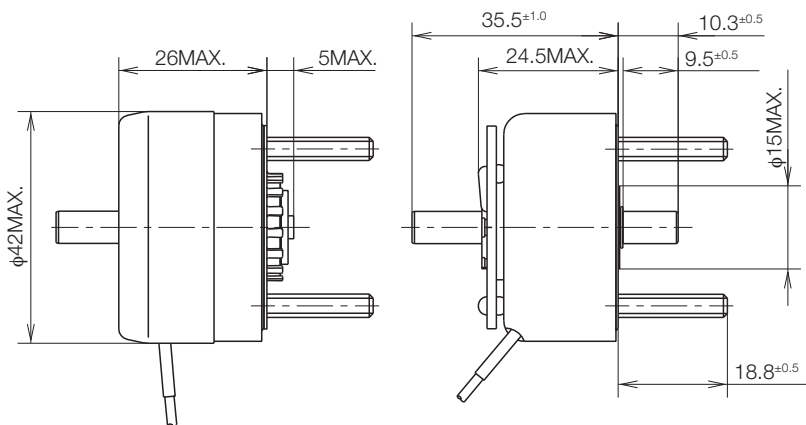

WITH A, D&R

WITH A&B

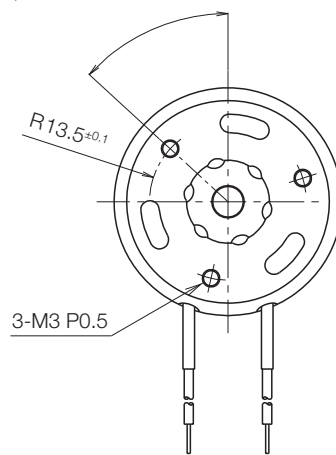

WITH T

COIL DATA

Heat sink : 160×160×3mm aluminum

Return spring torque : 0.0165~0.024 N·m

duty cycle= $\frac{\text{"on" time}}{\text{"on" time} + \text{"off" time}} \times 100\%$		100% continuous	75% or less	50% or less	25% or less	10% or less	
MAX. "on" time in seconds		∞	108	100	36	9	
watts at 20°C		12.5	16.5	25	50	125	
ampere-turns at 20°C		714	825	1000	1425	2250	
gross starting torque at 20°C (N·m)		25°	0.104	0.138	0.195	0.355	0.52
		35°	0.069	0.092	0.127	0.23	0.355
		45°	0.035	0.058	0.092	0.16	0.276
		67.5°	0.022	0.035	0.046	0.092	0.185
95°	0.012	0.022	0.035	0.058	0.115		
AWG no.	resistance Ω±10%(at 20°C)	no. turns	volts DC				
25	3.5	384	6.6	7.8	9.5	13	21
26	5.67	486	8.4	9.7	12	17	27
27	8.76	600	11	13	16	22	35
28	13.8	748	13	15	18	26	42
29	22.6	975	17	19	23	33	52
30	34.8	1190	21	25	30	42	67
31	56.7	1520	27	31	38	54	85
32	88.3	1908	35	41	49	70	110
33	138	2360	43	50	60	86	138
34	216	2904	53	61	75	106	168
35	351	3725	67	78	95	132	213
36	480	4000	85	98	119	169	268
37	720	4950	105	121	147	210	332
38	1150	6200	132	153	185	264	—
39	1920	8350	166	191	232	332	—
40	3000	10000	210	250	300	—	—