

# SIZE301C, 301F PUSH PULL SOLENOID

UNIT : mm  
SHOWN ENERGIZED

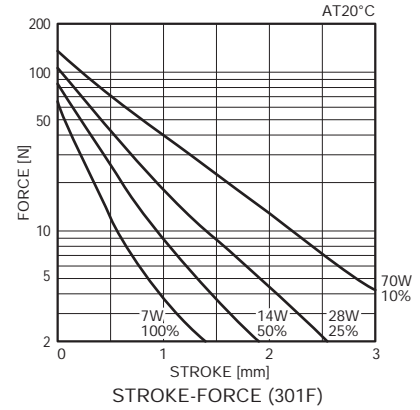

WEIGHT : 56g  
PLUNGER(C): 16g  
PLUNGER(F): 14g

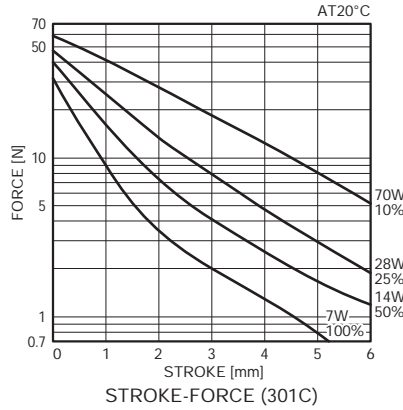
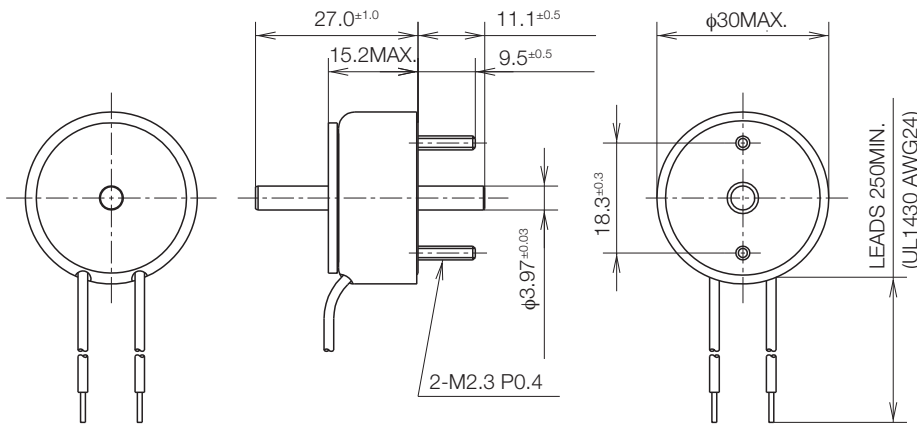
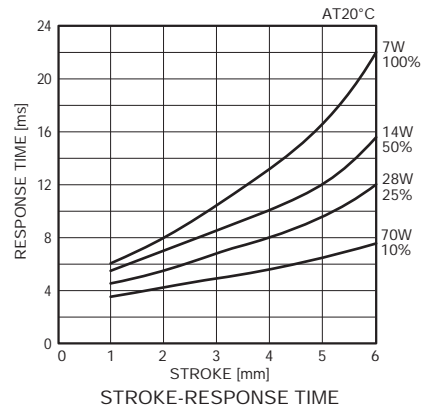

## COIL DATA

Heat sink : 90×90×3mm aluminum

duty cycle= $\frac{\text{"on" time}}{\text{"on" time} + \text{"off" time}} \times 100\%$			100% continuous	50% or less	25% or less	10% or less
MAX. "on" time in seconds			∞	100	36	7
watts at 20°C			7	14	28	70
ampere-turns at 20°C			425	602	849	1350
AWG no.	resistance $\Omega_{\pm 10\%}$ (at 20°C)	no. turns	volts DC			
26	1.96	231	3.5	5	7.1	11
27	3.16	296	4.5	6.3	8.9	14
28	5.1	378	5.6	8	11	18
29	6.94	423	7.1	10	14	22
30	11	530	8.9	13	18	28
31	16.9	649	11	16	22	36
32	28.3	858	14	20	28	45
33	42.8	1036	18	25	35	56
34	69.6	1312	22	32	45	71
35	112	1674	28	39	56	89
36	148	1765	35	50	71	112
37	221	2090	45	63	89	142
38	352	2650	56	80	112	178
39	568	3380	71	100	141	224
40	882	4200	89	126	178	283